

**UNLEASH
YOUR INNER**

**AVON
FITNESS**

**BEAST
BUILD**

**LIKE NEVER
BEFORE**

www.avonfitnessmachines.com

#RedefiningFitness

Power Up
Your *Workout*
Game



**AVON
FITNESS**

Avon Group Corporate Office





About us

Welcome to Avon Fitness where your journey to a healthier, stronger, and more vibrant life begins. Founded on the principles of dedication, innovation, and community, we strive to inspire and empower individuals to achieve their fitness goals and embrace a lifestyle of wellness.

At Avon we believe that fitness is not just about physical strength, but also about mental resilience and overall well-being. Our mission is to provide top-quality fitness products and services that cater to all levels of fitness enthusiasts, from beginners to seasoned athletes.

Raised and nurtured by the flagship Avon Cycles Limited of the AVON Group of Ludhiana, we are proud inheritors of its more than six decades old and meticulously built trust of the consumer. Our journey began with a simple vision: to create a fitness brand that combines cutting-edge technology with a deep understanding of our customers' needs.

QUALITY

We are committed to providing products and services of the highest quality, ensuring that our customers receive the best tools to achieve their fitness goals.

INNOVATION

We continuously seek out the latest advancements in fitness technology and methodology to bring you cutting-edge solutions that enhance your performance and well-being.

PASSION

Our passion for fitness drives everything we do. We are dedicated to inspiring and motivating others to embrace a healthier lifestyle and realize their full potential.

Our Fitness Partners



MYND SERIES

AVON FITNESS



MYND SERIES

MYND Series, a classic strength training line by AVON FITNESS, which delivers maximum durability and performance. With its solid construction and ergonomic design, the MYND Series ensures both safety and comfort. For exercisers, its smooth biomechanics and heavy-duty framework guarantee a powerful, effective, and long-lasting training experience

HIGH TENSILE TUBES

Flat Rectangular Tube 50x100 mm of main frame gracefully combine elegance and High Tensile strength.

STURDY STEEL COVER

Engineered with a robust steel shield for enhanced stability and reliability. Strong steel housing provides both safety and a premium finish.

PU LEATHERIZED SEATS

Exquisite Leather Texture - Combining Elegance, Luxury, Support & Durability.

PD COATING PAINT

Offers Excellent, Abrasion resistance and Bonderized for long-lasting protection to rust.



70+ Years Brand



Imported Range



Premium Quality



Quality Tested



Ergonomic Design



Aesthetic Appealing

MD 607

PEARL DELT / PEC FLY

- Frame Tube : High Tensile Steel
- Seat Cushion : PU Leatherized
- Cover : Sturdy Steel
- Cable : 6 mm Thickness
- Paint : Two Round Powder Coating
- Size : 1250x1300x2022 mm
- Weight Stack : 100 Kg.
- N.W / G.W : 210 Kg. / 250 Kg.



MD 608

CHEST PRESS

- Frame Tube : High Tensile Steel
- Seat Cushion : PU Leatherized
- Cover : Sturdy Steel
- Cable : 6 mm Thickness
- Paint : Two Round Powder Coating
- Size : 1360x1040x1580 mm
- Weight Stack : 100 Kg.
- N.W / G.W : 209 Kg. / 249 Kg.





70+ Years Brand



Imported Range



Premium Quality



Quality Tested



Ergonomic Design



Aesthetic Appealing

MD 609

DIP / CHIN ASSIST

- Frame Tube : High Tensile Steel
- Seat Cushion : PU Leatherized
- Cover : Sturdy Steel
- Cable : 6 mm Thickness
- Paint : Two Round Powder Coating
- Size : 1530x1190x2250 mm
- Weight Stack : 90 Kg.
- N.W / G.W : 290 Kg. / 330 Kg.



MD 612

BICEPS CURL

- Frame Tube : High Tensile Steel
- Seat Cushion : PU Leatherized
- Cover : Sturdy Steel
- Cable : 6 mm Thickness
- Paint : Two Round Powder Coating
- Size : 1270x1420x1580 mm
- Weight Stack : 80 Kg.
- N.W / G.W : 210 Kg. / 238 Kg.





70+ Years Brand



Imported Range



Premium Quality



Quality Tested



Ergonomic Design



Aesthetic Appealing

MD 613 LAT PULL DOWN

- Frame Tube : High Tensile Steel
- Seat Cushion : PU Leatherized
- Cover : Sturdy Steel
- Cable : 6 mm Thickness
- Paint : Two Round Powder Coating
- Size : 1260x1200x2120 mm
- Weight Stack : 100 Kg.
- N.W / G.W : 185 Kg. / 225 Kg.



MD 644 PULLEY LOW ROW

- Frame Tube : High Tensile Steel
- Seat Cushion : PU Leatherized
- Cover : Sturdy Steel
- Cable : 6 mm Thickness
- Paint : Two Round Powder Coating
- Size : 1640x1065x1580 mm
- Weight Stack : 100 Kg.
- N.W / G.W : 191 Kg. / 225 Kg.





70+ Years Brand



Imported Range



Premium Quality



Quality Tested



Ergonomic Design



Aesthetic Appealing

MD 647 SEATED ROW

- Frame Tube : High Tensile Steel
- Seat Cushion : PU Leatherized
- Cover : Sturdy Steel
- Cable : 6 mm Thickness
- Paint : Two Round Powder Coating
- Size : 1180x1268x1580 mm
- Weight Stack : 100 Kg.
- N.W / G.W : 207 Kg. / 247 Kg.



MD 648 TRICEPS DIP

- Frame Tube : High Tensile Steel
- Seat Cushion : PU Leatherized
- Cover : Sturdy Steel
- Cable : 6 mm Thickness
- Paint : Two Round Powder Coating
- Size : 1292x1172x1580 mm
- Weight Stack : 100 Kg.
- N.W / G.W : 206 Kg. / 246 Kg.





70+ Years Brand



Imported Range



Premium Quality



Quality Tested



Ergonomic Design



Aesthetic Appealing

MD 654

LEG EXTENSION / PRONE LEG CURL

- Frame Tube : High Tensile Steel
- Seat Cushion : PU Leatherized
- Cover : Sturdy Steel
- Cable : 6 mm Thickness
- Paint : Two Round Powder Coating
- Size : 1710x1008x1580 mm
- Weight Stack : 100 Kg.
- N.W / G.W : 226 Kg. / 266 Kg.



MD 671

BICEPS CURL / TRICEPS

- Frame Tube : High Tensile Steel
- Seat Cushion : PU Leatherized
- Cover : Sturdy Steel
- Cable : 6 mm Thickness
- Paint : Two Round Powder Coating
- Size : 1250x1072x1580 mm
- Weight Stack : 80 Kg.
- N.W / G.W : 212 Kg. / 252 Kg.





70+ Years Brand



Imported Range



Premium Quality



Quality Tested



Ergonomic Design



Aesthetic Appealing

MD 672

LAT PULL DOWN / LOW ROW



- Frame Tube : High Tensile Steel
- Seat Cushion : PU Leatherized
- Cover : Sturdy Steel
- Cable : 6 mm Thickness
- Paint : Two Round Powder Coating
- Size : 2086x1220x2200 mm
- Weight Stack : 100 Kg.
- N.W / G.W : 210 Kg. / 250 Kg.

MD 673

MULTI PRESS



- Frame Tube : High Tensile Steel
- Seat Cushion : PU Leatherized
- Cover : Sturdy Steel
- Cable : 6 mm Thickness
- Paint : Two Round Powder Coating
- Size : 1927x1347x1580 mm
- Weight Stack : 100 Kg.
- N.W / G.W : 239 Kg. / 280 Kg.



70+ Years Brand



Imported Range



Premium Quality



Quality Tested



Ergonomic Design



Aesthetic Appealing

MD 674

LEG CURL / LEG EXTENSION

- Frame Tube : High Tensile Steel
- Seat Cushion : PU Leatherized
- Cover : Sturdy Steel
- Cable : 6 mm Thickness
- Paint : Two Round Powder Coating
- Size : 1600x1076x1580 mm
- Weight Stack : 100 Kg.
- N.W / G.W : 232 Kg. / 272 Kg.



MD 676

ABDOMINAL CRUNCH / BACK EXTENSION

- Frame Tube : High Tensile Steel
- Seat Cushion : PU Leatherized
- Cover : Sturdy Steel
- Cable : 6 mm Thickness
- Paint : Two Round Powder Coating
- Size : 1130x1026x1580 mm
- Weight Stack : 100 Kg.
- N.W / G.W : 195 Kg. / 230 Kg.





70+ Years Brand



Imported Range



Premium Quality



Quality Tested



Ergonomic Design



Aesthetic Appealing

MD 677 ADDUCTOR / ABDUCTOR

- Frame Tube : High Tensile Steel
- Seat Cushion : PU Leatherized
- Cover : Sturdy Steel
- Cable : 6 mm Thickness
- Paint : Two Round Powder Coating
- Size : 1694x625x1580 mm
- Weight Stack : 80 Kg.
- N.W / G.W : 210 Kg. / 250 Kg.



MD 623 SUPER BENCH

- Frame Tube : High Tensile Steel
- Seat Cushion : PU Leatherized
- Paint : Two Round Powder Coating
- Size : 1620x760x810 mm
- N.W / G.W : 38 Kg. / 40 Kg.

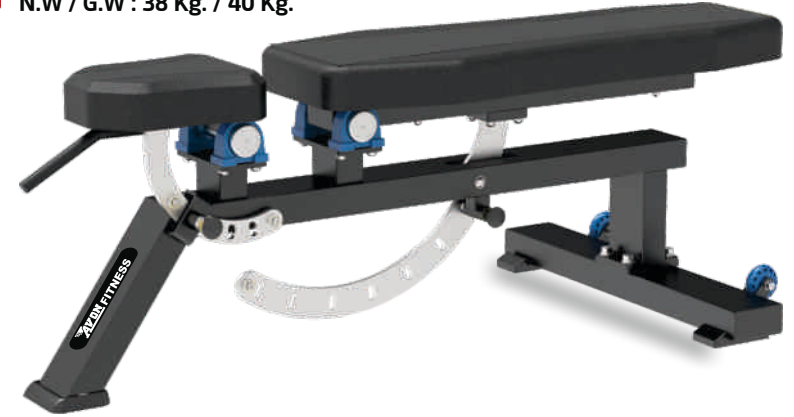

MD 624 OLYMPIC DECLINE BENCH

- Frame Tube : High Tensile Steel
- Seat Cushion : PU Leatherized
- Paint : Two Round Powder Coating
- Size : 2060x1780x1090 mm
- N.W / G.W : 70 Kg. / 85 Kg.





70+ Years Brand



Imported Range



Premium Quality



Quality Tested



Ergonomic Design



Aesthetic Appealing

MD 625 OLYMPIC INCLINE BENCH

- Frame Tube : High Tensile Steel
- Seat Cushion : PU Leatherized
- Paint : Two Round Powder Coating
- Size : 2010x1780x1400 mm
- N.W / G.W : 92 Kg. / 107 Kg.



MD 628 BACK EXTENSION

- Frame Tube : High Tensile Steel
- Seat Cushion : PU Leatherized
- Paint : Two Round Powder Coating
- Size : 1400x1200x1050 mm
- N.W / G.W : 60 Kg. / 75 Kg.



MD 626 OLYMPIC FLAT BENCH

- Frame Tube : High Tensile Steel
- Seat Cushion : PU Leatherized
- Paint : Two Round Powder Coating
- Size : 1730x1780x1220 mm
- N.W / G.W : 60 Kg. / 75 Kg.



MD 629 VERTICAL KNEE UP / DIP

- Frame Tube : High Tensile Steel
- Seat Cushion : PU Leatherized
- Paint : Two Round Powder Coating
- Size : 1270x710x1600 mm
- N.W / G.W : 76 Kg. / 91 Kg.





70+ Years Brand



Imported Range



Premium Quality



Quality Tested



Ergonomic Design



Aesthetic Appealing

MD631 SQUAT RACK

- Frame Tube : High Tensile Steel
- Seat Cushion : No Seat
- Paint : Two Round Powder Coating
- Size : 1850x1730x1800 mm
- N.W / G.W : 115 Kg. / 143 Kg.



MD633 3 IN 1 OLYMPIC BENCH

- Frame Tube : High Tensile Steel
- Seat Cushion : PU Leatherized
- Paint : Two Round Powder Coating
- Size : 2200x1780x1400 mm
- N.W / G.W : 127 Kg. / 157 Kg.



MD632 GLUTE HAM RAISE MACHINE

- Frame Tube : High Tensile Steel
- Seat Cushion : PU Leatherized
- Paint : Two Round Powder Coating
- Size : 1680x860x1050 mm
- N.W / G.W : 90 Kg. / 75 Kg.



MD684 SISSY SQUAT

- Frame Tube : High Tensile Steel
- Seat Cushion : PU Leatherized
- Paint : Two Round Powder Coating
- Size : 1065x635x470 mm
- N.W / G.W : 29.5 Kg. / 32 Kg.

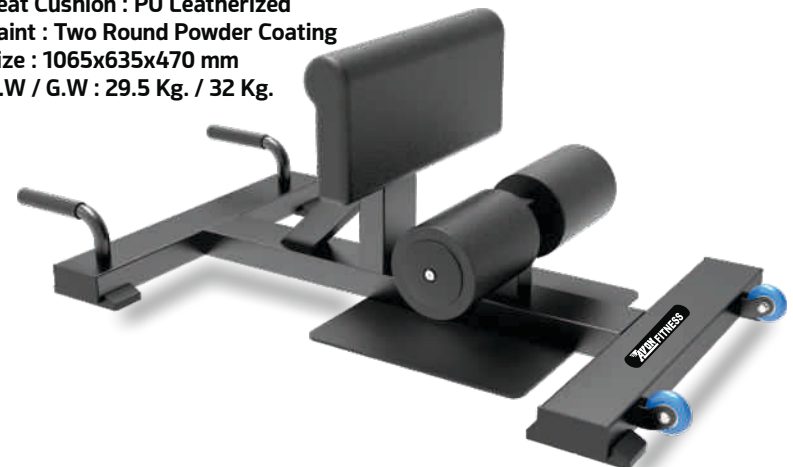



SCAN TO EXPLORE
OUR PRODUCTS RANGE



AVON FITNESS MACHINES PVT. LTD.

B-XXIX-476/9, Giaspura, Ludhiana-141003. Punjab
Contact: 87250-94200, Phone: 0161-5196154
E-mail: enquiry@avonfitnessmachines.com